

# AirSource®

## Heavy Duty A/C Components

## SERVICE BULLETIN

### EXAMINING CLUTCH FAILURES IN THE FIELD

This guide can be used as a reference to diagnose clutch failures, and is specifically designed to help you differentiate between unwarrantable clutch failures and those that would normally fall under possible warranty consideration. Next to hose leaks and compressors, clutches represent the next highest rate of failure of any a/c component. Use of this guide will enable mechanics to properly diagnose and observe more closely the primary causes of clutch failures. Observance and examination of both the compressor and clutch during diagnosis will greatly improve your analysis in determining exactly what happened. Since subsequent problems or failures often happen as a result of primary failure causes, this guide is divided into the following sections:

- A. CLUTCH COMPONENTS & TERMINOLOGY
- B. CLUTCH RELATED FAILURES
- C. COMPRESSOR RELATED FAILURES & CAUSES
- D. INSTALLATION RELATED FAILURES
- E. SUMMARY FAILURE CHART

#### A. CLUTCH COMPONENTS & TERMINOLOGY

To assist you in analyzing clutch failures, a diagram of a typical clutch assembly is shown. This diagram should be used as a reference when attempting to determine the cause of failures in the various components of the clutch assembly. The terminology used below will be referred to throughout this Service Bulletin.

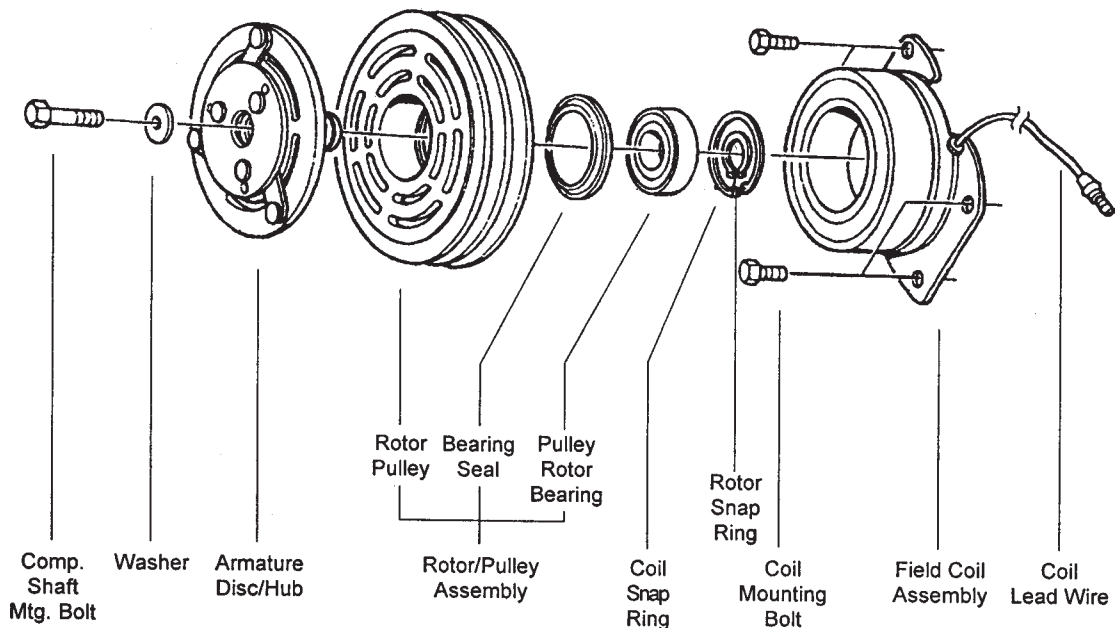

## **B. CLUTCH RELATED FAILURES**

The following are the most frequent symptoms and causes of clutch related problems.

### **1. Burnt Hub, Pulley, and/or Coil**

Inadequate voltage to the coil will result in overheating of the internal winding and cause the clutch hub to slip against the face of the pulley. A compressor in the stages of failing due to slugging or loss of lubrication, or operating under a high pressure condition will cause the clutch to slip. The slipping occurs continuously during compressor operation and can subject both the clutch and coil to extreme temperatures up to 1,200 degrees F. This will quickly destroy the clutch and its internal components. Visual evidence of this type of failure can be found in the illustrations on page 6. This type of failure is not warranted.

### **2. Bearing Failure**

Bearing failures are usually caused by system problems. Very seldom is a bearing itself the culprit of a failed or locked up compressor. For example, if the clutch slips severely due to a high pressure or low voltage condition, or due to compressor slugging, the excessive heat generated by the slipping will quickly melt and destroy the bearing seal. The bearing then loses its grease and locks up or falls apart, usually destroying the clutch in the process. This type of bearing failure is not covered under warranty, since the bearing was not the root cause of the problem. Warranty may be considered only if the bearing is intact, and there is no evidence of excessive heat, a compressor or a/c system problem, or signs of installation related problems. Manufacturing defects in clutch bearings are rare, and warranty allowances are usually associated with excessive noise symptoms only (see following condition).

### **3. Noisy Bearing**

If the complaint is noise related only, a defective clutch pulley bearing could be the source of the problem. Check for a rough or poorly operating bearing by holding the clutch armature hub stationary, and rotating just the pulley. If excessive noise or difficulty in ease of rotation is observed, the bearing may be suspect. However, as with the failed bearing situation described above, several factors can cause the bearing to become noisy or rough in operation. A rough bearing can also be one that is in the early stages of failing due to system problems involving extreme heat. This is usually the case if the compressor clutch has been operating sufficiently for some time and then becomes noisy. Most factory bearing defects become evident in the first hours of compressor operation. Warranty consideration for failed compressors and clutches described as noisy will be provided only if there are no obvious signs that the failure was caused by other factors.

### **4. Unburnished Clutch**

Burnishing is the cycling of the clutch to allow a wearing in of the engagement surface area. The reason for burnishing a clutch is to increase the initial starting torque. Most technicians fail to follow this important procedure when replacing a compressor or clutch. An unburnished clutch can produce a low torque condition, causing the clutch to slip and thereby fail. When replacing a clutch or compressor & clutch assembly, follow this important burnishing procedure. Run the engine at 1,500 to 2,500 RPM. Using the controls on the dash, cycle the clutch ON and OFF at a rate of 10 to 15 times per minute for a total of 50 cycles minimum. This should bring the clutch up to operating torque capacity.

### **5. Improper Rotor to Hub Air Gap**

An incorrect air gap can cause a clutch to engage or disengage improperly. This is particularly true on Sanden, Seltec, and Frigidaire/GMC style compressor clutches. Before operating a compressor of this type, check the hub/armature to rotor/pulley air gap. Check the required specifications for your particular type of compressor clutch in the illustrated section of the A/C parts catalog. These clutches may involve adding or removing shims to properly gap the hub. New manufactured compressor & clutch assemblies are properly gapped at the factory. Most clutch failures or problems relating to improper air gap can be traced to improper clutch replacement in the field. Check to see if this applies before returning possible warranties.

### **6. Misaligned Belt or Use of Wrong Clutch**

In some cases clutch failure can be contributed to a slipping, under or over tensioned, or misaligned pulley belt. Further checking may discover that the wrong clutch (with improper mounting distance specifications) was installed onto the compressor. A clutch with as little as 1/8" offset in alignment can cause problems. Sometimes a misalignment condition can be traced to a cracked or loose compressor mount bracket on the engine. Look for excessive wear and/or indications of rubbing on the inside of the pulley groove before returning possible warranties.

### **7. Open Circuit inside Field Coil**

This type of condition is rare, and can only be verified by removing the clutch pulley and hub from the compressor. The field coil core is held in place by an outer epoxy resin. If the bond between the epoxy and the winding fails, the coil may be subject to move, which could lead to a break in the coil wire, producing an inoperative clutch. With the exception of a fine crack around the outer diameter of the epoxy, there is no outward indication of a problem. However, the open circuit can be found with a resistance (ohm) meter. If an open circuit is found, with no evidence of melted resin or installation damage, the coil itself may be warranted.

### **8. Failed Field Coil Mounting Flange Welds**

This condition is specific only to CCI/York/Tecumseh style clutches. The field coil assembly consists of a magnetic field core that encloses the coil, and a flange which mounts onto the compressor. The field core and flange are assembled at the factory, joined together by spot welds. Although it seldom occurs, a faulty spot weld will cause rubbing between the outside of the field core and inside of the pulley, eventually causing an open circuit and inoperative clutch. Be aware that in most cases involving failed welds and broken coil flanges, a severe vibration problem usually exists. This is especially true on Detroit Series 60 engines. In some cases the vibration is so extreme that the screws holding the coil onto the compressor will vibrate loose, causing the clutch assembly to become unattached from the compressor shaft. Without a secure mount, the clutch and coil will literally be torn apart by the force of the drive train belt attempting to turn the clutch pulley. The compressor shaft is usually also destroyed in the process. An occurrence of this nature voids all warranty on both the compressor and clutch.

### **9. Faulty Lead Wire**

If the lead wire connected to the field coil is faulty, the clutch becomes inoperative. This will be evident at the time of installation, and seldom occurs afterwards. However, evidence of obviously damaged or cut lead wires is not a cause for warranty consideration.

## **C. COMPRESSOR RELATED FAILURES & CAUSES**

The following are the most frequent causes of clutch failures. These can all be traced to a problem in the compressor and/or a/c system. Please note that in nearly every case involving compressor related clutch failure, warranty is not applicable.

### **1. Seized or Slugging Compressor**

The clutch's function is to engage and disengage the compressor from the vehicle's accessory drive system. If there is a system problem that prevents proper rotation of the compressor input shaft while the clutch is energized, the clutch will slip. A slipping clutch can generate tremendous heat, up to 1,200 degrees F. In a matter of seconds, components can start to fail. There is a progression of effects generated from slipping, all leading to overall clutch and/or compressor failure.

Symptoms and causes are listed below:

#### **a.) Loss of Lubrication**

- 1.) Loss of refrigerant will also prevent oil from returning to the compressor causing binding or lockup.
- 2.) A blockage or restriction somewhere in the system will also inhibit or prevent oil return to the compressor, thereby causing slipping, binding, or lockup.

#### **b.) Excessive A/C System Pressure**

The following problems will all increase system pressure. Just as too high blood pressure causes the heart to overwork, and prematurely fail, excessive A/C system pressure can cause the compressor to overwork, begin to seize, and increase the torque requirements of the clutch. The clutch will begin to slip, which produces tremendous heat build-up. Resultant clutch and bearing failure follows.

##### **1.) Incorrect Amount of Oil in System**

Too much oil can cause compressor slugging and a slipping clutch. Excessive oil can accumulate in the a/c condenser, increasing system discharge pressures. Not enough oil will cause compressor binding and clutch slipping.

##### **2.) Inadequate Air Flow across the Condenser**

If the condenser is restricted internally, or has inadequate air flow across it, the result is a higher discharge pressure. This can cause the clutch to slip. Check the inlet and outlet temperatures of the condenser. A difference of over 35 degrees can indicate a problem. An inoperative or faulty radiator or condenser fan could also be suspect, or shutters not opening properly.

##### **3.) A Blockage in the High Pressure Side of the A/C System**

A blockage will cause the discharge pressure to increase and can cause clutch slipping. A blockage in the system can usually be pinpointed by an immediate temperature (pressure) drop just following the blockage. Remember that a rise in pressure means a rise in temperature, and vice versa.

##### **4.) System Overcharge**

An overcharged a/c system will cause pressures to increase and cause slipping. When checking for an overcharged system, remember to also check for the presence of non-condensables (air). This condition will also increase system pressures.

**(continued)**

### **C. COMPRESSOR RELATED FAILURES & CAUSES (cont.)**

#### **2. Leaking Compressor Shaft Seal**

Another clutch failure that can be attributed to a system problem is a failed bearing due to impingement by compressor oil. This may occur if the seal on the compressor shaft leaks compressor oil, and finds its way into the clutch bearing. This oil can contaminate the bearing grease, causing it to be less effective, and also lead to grease purging through the bearing seals. The result is a gritty or failed bearing. Remember that an excessive heat condition in the system can also cause a shaft seal failure.

#### **3. Mis-Machined Compressor Mounting Boss**

If there is a dimensional problem with the mounting bosses used for attaching the field coil assembly to the compressor, an interface condition may be created between the field coil and rotor assembly. This problem is usually associated with poor quality remanufactured compressors.

#### **4. Re-Machined Compressor Shaft**

During the course of remanufacturing a compressor, the taper of the input shaft may be re-machined. As a result, the shaft will be shortened and less clearance will remain between the clutch and the compressor. This can create interference and hinder the rotation of the rotor assembly. Again, this problem is usually linked to poor quality remanufacturers.

**Symptoms of the preceding problems are as follows. See the illustrations on page 5:**

##### **1.) Discoloration of Pulley and/or Armature Disc**

The extreme heat generated from slipping will quickly cause the component(s) to take on a discolored appearance. They will appear "frosted", or "blued", or even charred.

##### **2.) Melting of Rubber Spacers in Armature**

If the slipping continues, the temperature can reach a point where the rubber spacers between the armature plate and disc begin to melt. Not all clutches utilize rubber spacers.

##### **3.) Melting of Epoxy in Field Coil**

The extreme heat can also affect the field coil, causing the epoxy to show visual signs of melting or "charring". Under extreme situations, the coil winding will become exposed and/or unseated.

##### **4.) Melting of Bearing Seal**

The heat will eventually cause the bearing seal to melt, allowing the grease to escape. Without grease to lubricate the bearing, it is quickly destroyed.

### **D. Installation Related Failures**

The following are the most frequent causes of installation related clutch failures. Please note that clutch failures resulting from improper installation are not warrantable.

#### **1. Loose Field Coil Mounting Bolts**

If the bolts used to mount the field coil are not tightened adequately, vibration in the vehicle will cause the coil to become loose. Eventually the field coil will begin to contact the rotor assembly, as evidenced by rubbing on the field core outer diameter. This rubbing may generate heat that melts the field coil epoxy, leading to an open circuit and inoperative clutch. This condition is specific to CCI/York/Tecumseh style compressors. The replacement clutches for these type of compressors are now normally supplied with special locktite treated fasteners. Use of these fasteners normally solve this kind of problem.

#### **2. Short or Open Circuit in Field Coil Wire**

If the clutch lead wire is routed in such a way as to subject it to possible rubbing or cutting by another object, the wire's insulation can be rubbed through and the bare wire exposed. A short circuit or open circuit will likely develop, causing the clutch to become inoperative. This type of failure is evidenced by a lead wire worn down to bare metal in one or more locations along its length, or a lead wire that gets cut in half.

#### **3. Shaft Key not Seated Properly in Armature Hub**

If the key is not properly inserted into the keyway on the compressor input shaft during a clutch installation, a severe misalignment of the pulley relative to the shaft will occur. This misalignment will create interference between the rotor and field coil assemblies. Evidence of severe rubbing of the pulley on the field coil will be present.

#### **4. Improperly Installed or Wrong Snap Ring**

Use of a wrong snap ring, or an improperly installed snap ring on the field coil or pulley can cause the clutch to be noisy, fail to disengage, or in some cases come off. Resultant clutch damage can follow. This is especially true on some Ford FS6 compressor clutches, where several types and thicknesses of snap rings were originally used. Consult manual for further instructions.

**5. Mismatched Clutch Components**

Especially in the case of Ford FS6 and FX15/FS10 type clutches, complete replacement of the clutch and coil assembly is required. Original or replacement Ford O.E. clutch components cannot be mixed with aftermarket type clutch components (such as a Ford O.E. coil and an aftermarket pulley and hub). Mixing these different types of components together can cause clutch failure and/or faulty clutch operation.

**6. Improperly Installed Coil Ground Wire**

On CCI/York/Tecumseh style field coils, the ground wire terminal should be installed on top of the coil mounting flange. If the terminal is improperly installed underneath the flange, the alignment of the outer coil and inner pulley interface will be adversely affected and create the potential for rubbing between the rotor and coil assemblies.

**7. Use of Excessive Torque on Compressor Shaft Mounting Bolt**

Broken or twisted bolts are the result of excessive torque applied during installation, such as from use of an impact wrench. Check manufacturer's torque specifications when installing clutch hardware.

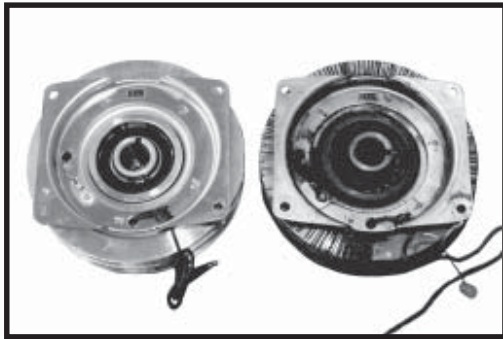

*Comparison of New Clutch and Clutch with Failed Rotor Assembly Bearing*

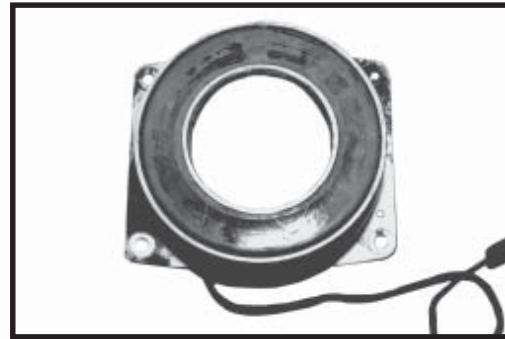

*Field Coil with Failed Epoxy Bond (Note Gap Around O.D. of Epoxy Ring)*

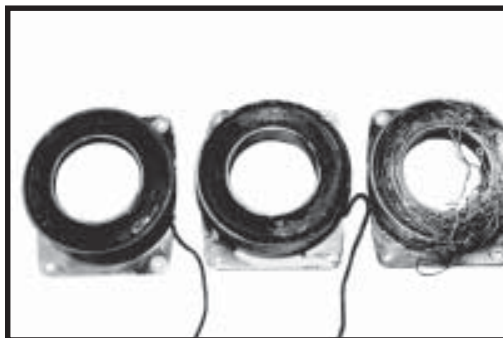

*Three Field Coils in Different Stages of Failure Due to Extreme Heat*

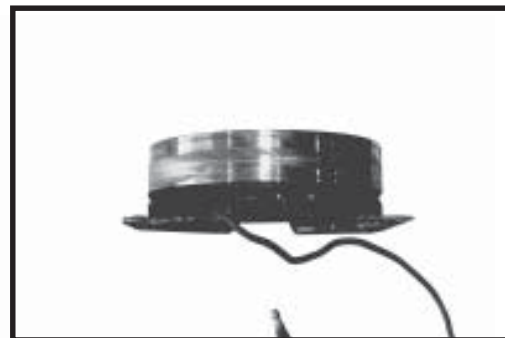

*Wear on O.D. of field Coil Assembly on Clutch with Elongated Field Coil Mounting Flange Holes*

**E. Failure Summary Chart - Use this chart to compare possible warranty clutches you have to return**

**IMPORTANT-ANSWER ALL QUESTIONS 1-19 BEFORE PROCEEDING TO EXPLANATION CHART  
(If any listed condition exists, answer YES)**

*Refer to the Failure Explanation(s) indicated on the following page.*

1. Are there obvious signs of discoloration (frosting, blueing, or charring) on the armature disc?  
**Yes** Go to A                      **No** go to Q
2. Do the rubber spacers (if equipped) on the armature backing plate show signs of melting, or are they missing altogether?  
**Yes** Go to A                      **No** go to Q
3. Does the bearing seal show signs of melting? Has grease escaped? Is the bearing stiff or seized or gritty?  
**Yes** Go to A                      **No** go to Q
4. Does the coil epoxy show signs of extreme heat exposure and melting? Is the coil wiring itself exposed in any area?  
**Yes** Go to A                      **No** go to Q
5. Are there signs the rotor has rubbed on the sides of field coil?  
**Yes** Go to B                      **No** go to Q
6. Is there wear on top of the field coil, or on top of the bearing pocket?  
**Yes** Go to C                      **No** go to Q
7. Are the coil mounting flange bolt holes elongated or damaged?  
**Yes** Go to D                      **No** go to Q
8. Is the insulation on the coil lead wire cut, kinked, or bare in any spot?  
**Yes** Go to E                      **No** go to Q
9. Is the coil wire missing altogether?  
**Yes** Go to F                      **No** go to Q
10. Does the armature hub key-way appear to be damaged?  
**Yes** Go to G                      **No** go to Q
11. Is there an imprint of a wire terminal on the bottom side of the coil mounting flange?  
**Yes** Go to H                      **No** go to Q
12. Does the clutch bearing feel rough or gritty?  
**Yes** Go to I                      **No** go to Q
13. Is the clutch bearing seized or tight? Is the bearing and grease intact?  
**Yes** Go to J                      **No** go to Q
14. Is there a small crack or gap running along the outer diameter of the field coil epoxy ring?  
**Yes** Go to K                      **No** go to Q
15. Is the coil mounting flange destroyed, missing, or starting to separate?  
**Yes** Go to L                      **No** go to Q
16. Is the clutch pulley/armature mounting bolt broken in half?  
**Yes** Go to M                      **No** go to Q
17. Is the problem noise related, with all the clutch components (incl. bearing) appearing to be OK?  
**Yes** Go to N                      **No** go to Q
18. Does the clutch fail to engage or disengage properly?  
**Yes** Go to O                      **No** go to Q
19. Does the clutch slip, with all other system components appearing to function properly?  
**Yes** Go to P                      **No** go to Q

**Failure Explanations (refer to Failure Summary Chart on previous page)**

- A. Failure of clutch is due to (1) a seized or slugging compressor or (2) may be the result of excessive a/c system pressure or (3) insufficient voltage to coil. Clutch may be seized or burnt, or slipping. Evidence of extreme heat build-up. **No warranty allowed. Read all of Section C (both causes and symptoms). Note: If the problems which caused the clutch to fail are not remedied, the probability is good that simply installing another clutch will result in a repeated failure.**
- B. Failure of clutch is due to (1) improper procedures used during clutch installation or (2) mismatched clutch components used during installation or (3) a compressor boss dimension problem. Complaint may be a noisy or inoperative clutch. Bearing and armature both should be OK. **No warranty allowed. Read Sections C3., and D1.,D3.,D4.,D5., and D6.**
- C. Failure of clutch is most likely due to an improperly machined compressor input shaft, and is not a clutch defect. Clutch may be seized. **No warranty allowed. Read Section C4.**
- D. Failure of clutch is due to loose field coil mounting bolts. A severe vibration condition may exist. Coil may have an open circuit. **No warranty allowed. Read Section D1.**
- E. Failure of clutch is due to a short or open circuit in the field coil lead wire. Normally associated with improper installation routing of wire. Complaint may be an erratic or inoperative clutch. **No warranty allowed. Read Section D2.**
- F. Failure of clutch is due to a faulty lead wire solder connection to coil body. Check to see if failure is due to fatigue or connection, or improper installation, or possibly damaged during removal. Armature and rotor should both be OK. **Possible warranty if not cut/ripped loose. Read Sections B9., and D2. and 6.**
- G. Failure of clutch is due to improper installation. Shaft key not properly seated into shaft or hub. May be evidence of rubbing on coil and rotor. Clutch may be inoperative. **No warranty allowed. Read Section D3.**
- H. Failure of clutch was caused by improperly installing the coil ground wire under the coil mounting flange. May be evidence of rubbing on coil or rotor. **No warranty allowed. Read Section D6.**
- I. Possible defective bearing, if too noisy. Only if grease is intact, and armature and coil are both OK. **Possible warranty. Read Sections B2.,B3., and C2.**
- J. Bearing failure. Armature should be OK. No signs or symptoms of heat exposure should exist. Possible rubbing on outer diameter of coil. **Possible warranty (if intact). Read Section B2.**
- K. An open circuit may exist in the field coil. **Possible warranty.** Check the circuit for continuity to positively identify the coil as the source of the problem. Resistance will be infinite if coil has "open circuit". If coil has a "short circuit", resistance value will be between zero and 3.16 to 3.5 on 12-volt coils; and between zero and 13.3 on 24-volt coils. An ohmmeter with temperature compensation should be used for resistance specification tests. **Read Section B7.**
- L. Possibility of failed coil mounting flange welds. Coil outer diameter and inside of rotor will probably show signs of rubbing. Armature should be OK. Clutch is probably inoperative. **Possible warranty. Read Section B8.**
- M. Usually caused by using an impact wrench, or use of excessive torque when installing the clutch. Remainder of bolt threads can be found inside the compressor input shaft. **No warranty allowed. Read Section D7.**
- N. The noise may be due to a misaligned, improperly tensioned, or slipping belt. Or the possibility exists that either the clutch is incorrect or contains improperly installed components. Also check for a loose or cracked compressor mounting bracket. **No warranty allowed. Read Sections B6., and D4. and D5. Also see Belt Tension chart.**
- O. Clutch rotor/pulley and hub/armature may not be properly gapped. Clutch may have been improperly installed with wrong snap ring, or contain mismatched components. Follow proper installation procedures to gap the hub before submitting for warranty. Also check for adequate voltage to coil. If either procedure does not fix problem-**Possible warranty. Read Sections B5. and D4. and D5..**
- P. Clutch slippage can be contributed to a number of problems. Check first for proper voltage to coil. Diagnose electrical system and repair. **Read Sections B4., B5.,B6., and B7.; and all of Section C (both causes and symptoms); and D5. Also see Belt Tension chart. No warranty allowed.**
- Q. Did you continue to go through **all** remaining checks and observations (Steps 1-19)? If all tests pass OK, failure of clutch to operate correctly may be the result of insufficient voltage to coil (12.5 volts required; 10.5 to 10.8 volt minimum with all electrical accessories on), low voltage feedback from blower motor operation, or from other system electrical components. Consult vehicle service manual.